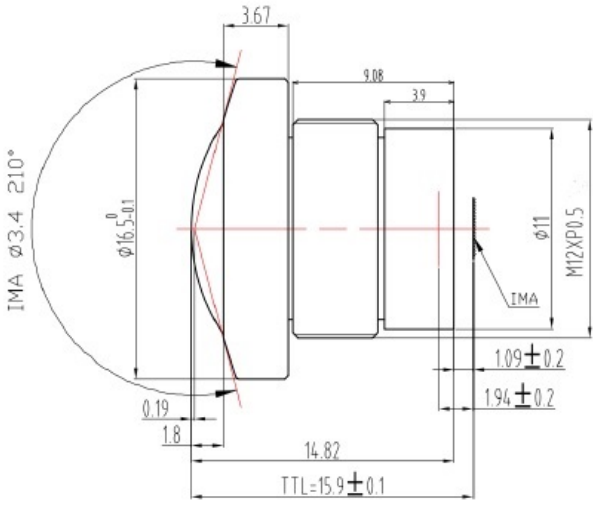

產品規格書 PRODUCT SPECIFICATION

鏡頭參數 Parameter of Lens		圖片 Photo (Just for Reference)	
型號 Model No	8088		
像面尺寸 Format(inch)	1/2.3"		
焦距 Focal-Length	1.05mm		
後焦距 Back Focal-Length	1.94mm		
通光量 Aperture(D/f')	F2.4		
解析度 Pixel	12MP		
介面 Mount	M12×0.5P		
畸變 Distortion	<19.2%		
視場角 Field of View	H		210°
	V		210°
	D		210°
光學總長 TTL	16mm		
尺寸 Dimension	Φ3.4*14.82mm		
重量 Weight	7g		
鏡頭結構 Lens Construction	7G+1IR		
操作溫度 Operating Temperature	-20℃~+80℃		

尺寸 Size	公差 Tolerance	
	尺寸 Dimension	公差 Tolerance
	X_XX	±0.02
	X_X	±0.05
X_	±0.10	
		

AMSL Lens

Hong Kong Office Address:
701, 7/F, TOWER 2, SILVERCORD, 30 CANTON ROAD, TSIM SHA TSUI, KOWLOON
Mandrin Factory Address:
#47, ROAD SHI YANG, HU MEN TOWN, CITY DONG GUAN, PROVINCE GUANG DONG, 523900
PHONE: +852 6672 1979/+86 185 2016 9594
WEBSITE: www.amsl-lens.biz

