

June 6, 2024

Version 1.0

Lens & Camera

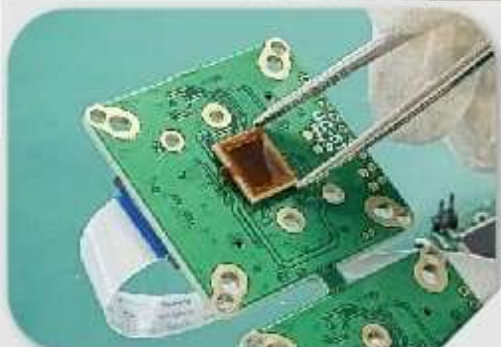

AMSL Lens-Cam

www.amsl-lens-cam.biz

www.amperems.biz

We design and manufacture the best lenses and camera modules!

AM
LS



Table of Contents

The Purpose of This Booklet	3
About AMSL Lens-Cam	3
Lens, 1/2.6"	4
Part #: 8065, M12, 1.77mm, 3MP, 180 deg, TTL13	4
Part #: 8066, M12, 2.88mm, 3MP, 90 deg, TTL15	5
Part #: 8069, M12, 2.8mm, 3MP, 180 deg	6
Part #: 8070, M12, 3.5mm, 3MP, 90 deg	7
Lens, 1/2.7"	8
Part #: 8049, M8, 3.2mm, 2MP, 16% Distortion, IP67	8
Part #: 8068, M8, 3mm, 3MP, No Distortion	9
Part #: 8071, M12, 8mm, 2MP	10
Part #: 8072, M12, 6mm, 3MP	11
Lens, 1/2.9"	12
Part #: 8075, M12, 2.1mm, 2MP, 35% Distortion	12
Part #: 8076, M12, 2.4mm, 3MP	13
Part #: 8077, M12, 4.4mm, 2MP	14
Lens, 1/3"	15
Part #: 8053, CS, 2.8mm, 5MP, 22% Distortion.....	15
Part #: 8055, M6, 4.3mm, 3MP, 1% Distortion.....	16
Part #: 8056, M6, 4.2mm, 3MP, 1% Distortion.....	17
Part #: 8057, M7, 1.9mm, 2MP, 26% Distortion.....	18
Part #: 8074, M12, 3.2mm, 2MP, 23% Distortion	19
Part #: 8097, M12, 2.8mm, 5MP, 1% Distortion.....	20
Lens, 1/4"	21
Part #: 8048, M8, 2.6mm, 2MP, 10.7% Distortion	21
Part #: 8058, M12, 0.88mm, 2MP, 19% Distortion	22
Part #: 8060, M7, 2.07mm, 5MP, 8.5% Distortion	23
Part #: 8061, M7.3, 2.2mm, 2MP, 16% Distortion	24
Part #: 8062, M9, 2.6mm, 5MP, 1.2% Distortion.....	25
Part #: 8063, M8, 2.23mm, 1.3MP, 13% Distortion, IP67	26
Part #: 8064, M8, 1.9mm, 2MP, 25% Distortion, IP67	27
Lens, 1/6"	28
Part #: 8052, M5.5, 3.15mm, 2MP	28
Part #: 8081, M6, 1.2mm, 2MP	29

Part #: 8082, M5.7, 1.0mm, 2MP	30
Lens, 1/10.5"	31
Part #: 8073, M3, 1.03mm, 1MP	31
Camera Module, 1MP	32
Part #: 8995, 1MP, GC1064+USB, 54x38	32
Part #: 9009, 1MP, OV9726 + USB, 60x8, long shape	33
Part #: 9024, 1MP, H62 + USB, 38x38	34
Camera Module, 2MP	35
Part #: 8986, 2MP, GC2053 + CVBS, 14 Dia, FPV	35
Part #: 9012, 2MP, OV2640 + MIPI, FPC, 120 Degree	36
Part #: 9022, 2MP, OS02G10 + MIPI, FPC	37
Part #: 9027, 2MP, SC2335 + CVBS, 32x32, 3.3v	38
Camera Module, 4MP	39
Part #: 8977, 4MP, OV4689 + MIPI, 38x38	39
Part #: 8978, 4MP, GC4653 + MIPI, FPC	40
Camera Module, 5MP	41
Part #: 8958, 5MP, IMX335 + MIPI, 38X38	41
Part #: 8959, 5MP, IMX335 + MIPI, FPC	42
Part #: 9006, 5MP, OV5647 + MIPI, 25x24, Raspberry Pi	43
Part #: 9017, 5MP, OV5648 + USB, 30x25	44
Part #: 9020, 5MP, OV5645 + MIPI, FPC, AF	45
Camera Module, 8MP	46
Part #: 8989, 8MP, OS08A20+ MIPI, FPC	46
Part #: 9014, 8MP, GC8034 + MIPI, FPC, AF	47
Camera Module, 11MP	48
Part #: 9025, 11MP, IMX214 + USB, 38x38	48
Camera Module, 13MP	49
Part #: 8980, 13MP, OV13850 + MIPI, FPC, AF	49
Dual Camera Module	50
Part #: 8981, 2MP, GC2053 + PS5268LT + USB, 80x17, 30FPS	50
Part #: 9001, 1MP, OV9281 + USB, 88x16, Sync, BW	51
Part #: 9002, 2MP, OV4689 + USB, 30FPS	52
Zoom-In Camera	53
Part #: 7096, 5MP Zoom x20 USB Camera	53
Part #: 7097, 8MP Zoom x20 USB Camera	54
Part #: 7098, 1080P Zoom x10 USB Camera	55

Order Form 56
We give you three easy ways to order 57

The Purpose of This Booklet

The purpose of this booklet is to advertise our lenses, camera modules, and completed cameras. ***However, this booklet may not list out our latest products, so please talk to our sales for more information!***

About AMSL Lens-Cam

The "AMSL Lens" & "AMSL Lens-Cam" brands are owned by Ampere Manufacturing and Supplies Ltd (HK Company Registration No.: 2927913).

AMSL Lens-Cam (the brand) was founded in 2017. It is a global leader in lens and camera module design and production, and its headquarter is located in Kowloon, Hong Kong. AMSL Lens-Cam currently has two manufacturing facility in Dongguan Guangdong China, and another one is in Xinxiang Henan China.

Not only does AMSL Lens-Cam various miniaturized lenses and camera modules, the AMSL (the Company) also produces PCB design-manufacturing, mold injection, and actively expands various product types to meet market demand.

- Master core lens-glasses technology.
- Elegant and talented design on camera module PCB.
- Great business relationship with main image sensor suppliers to make sure no supply shortage.
- 100% outgoing inspection, we provide the best the quality control.

Management Philosophy: Every employee is the part of the brand.

"Every employee is the part of the brand" is the management philosophy of AMSL Lens. From an innovative idea to product commercialization, the whole process is fully supported by AMSL (the Company). Talents are cultivated through the process and employees are able to fully display their skills in the workplace.

Lens, 1/2.6"

Part #: 8065, M12, 1.77mm, 3MP, 180 deg, TTL13

鏡頭參數 Parameter of Lens		圖片Photo (Just for Reference)	
型號 Model No	8065	TBD	
像面尺寸 Format(inch)	1/2.6"		
焦距 Focal-Length	1.77 mm		
後焦距 Back Focal-Length	3.45mm		
通光量 Aperture(D/F)	F2.2		
解析度 Pixel	3MP		
介面 Mount	M12×0.5P		
視場角Field of View	H		172°
	V		108°
	D		192°
畸變 Distortion	<16%		
尺寸 Dimension	Φ14*9.97mm		
鏡頭結構 Lens Construction	5E+R 650		
重量 Weight	5g		
操作溫度 Operating Temperature	-10℃~+70℃		

尺寸Size		公差Tolerance	
		尺寸Dimension	公差Tolerance
		0-10	±0.05
		10-30	±0.10
		30-120	±0.20



AMSL Lens

Hong Kong Office Address:
701, 7/F, TOWER 2, SILVERCORD, 30 CANTON ROAD, TSIM SHA TSUI, KOWLOON

Mandrin Factory Address:
#47, ROAD SHI YANG, HU MEN TOWN, CITY DONG GUAN, PROVINCE GUANG DONG, 523900

PHONE: +852 6672 1979/+86 185 2016 9694
WEBSITE: www.amsl-hens.biz

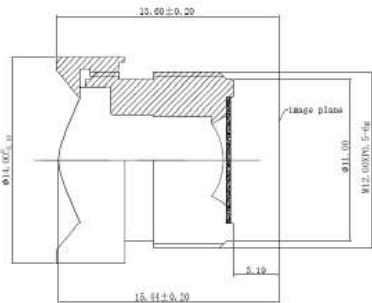
Part #: 8066, M12, 2.88mm, 3MP, 90 deg, TTL15

鏡頭參數 Parameter of Lens			圖片Photo (Just for Reference)											
型號 Model No	8066													
像面尺寸 Format(inch)	1/2.6"													
焦距 Focal-Length	2.88mm													
後焦距 Back Focal-Length	3.19mm													
通光量 Aperture(D/F)	F2.4													
解析度 Pixel	3MP													
介面 Mount	M12×0.5P													
視場角Field of View	H	90.5°												
	V	59°												
	D	98°												
畸變 Distortion	<1%													
尺寸 Dimension	Φ14*12.41mm													
鏡頭結構 Lens Construction	5E+R 650													
重量 Weight	6g													
操作溫度 Operating Temperature	-10℃~+70℃													
尺寸Size			<table border="1"> <thead> <tr> <th colspan="2">公差Tolerance</th> </tr> <tr> <th>尺寸Dimension</th> <th>公差Tolerance</th> </tr> </thead> <tbody> <tr> <td>0-10</td> <td>±0.05</td> </tr> <tr> <td>10-30</td> <td>±0.10</td> </tr> <tr> <td>30-120</td> <td>±0.20</td> </tr> </tbody> </table>		公差Tolerance		尺寸Dimension	公差Tolerance	0-10	±0.05	10-30	±0.10	30-120	±0.20
	公差Tolerance													
尺寸Dimension	公差Tolerance													
0-10	±0.05													
10-30	±0.10													
30-120	±0.20													
AMSL Lens Hong Kong Office Address: 701, 7/F, TOWER 2, SILVERCORD, 30 CANTON ROAD, TSIM SHA TSUI, KOWLOON Mandrin Factory Address: #47, ROAD SHI YANG, HU MEN TOWN, CITY DONG GUAN, PROVINCE GUANG DONG, 523900 PHONE: +852 6672 1979/+86 185 2016 9594 WEBSITE: www.amsl-lens.biz														

Part #: 8069, M12, 2.8mm, 3MP, 180 deg

鏡頭參數 Parameter of Lens		圖片 Photo (Just for Reference)	
型號 Model No	8069		
像面尺寸 Format(inch)	1/2.6"		
焦距 Focal-Length	2.8mm		
後焦距 Back Focal-Length	5.96mm		
通光量 Aperture(D/F)	F2.8		
解析度 Pixel	3MP		
介面 Mount	M12×0.5P		
視場角 Field of View	H		130°
	V		98°
	D		170°
畸變 Distortion	-15.00%		
尺寸 Dimension	Φ17.5*18.54mm		
鏡頭結構 Lens Construction	6G+IR 650		
重量 Weight	6g		
操作溫度 Operating Temperature	-10℃~+70℃		

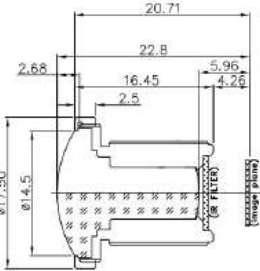
尺寸 Size		公差 Tolerance	
		尺寸 Dimension 公差 Tolerance	
		0-10	±0.05
		10-30	±0.10
30-120	±0.20		

AMSL Lens

Hong Kong Office Address:
701, 7/F, TOWER 2, SILVERCORD, 30 CANTON ROAD, TSIM SHA TSUI, KOWLOON

Mandrin Factory Address:
#47, ROAD SHI YANG, HU MEN TOWN, CITY DONG GUAN, PROVINCE GUANG DONG, 523900

PHONE: +852 6672 1979/+86 185 2016 9694
WEBSITE: www.amsl-lens.biz



Part #: 8070, M12, 3.5mm, 3MP, 90 deg

鏡頭參數 Parameter of Lens		圖片 Photo (Just for Reference)	
型號 Model No	8070		
像面尺寸 Format(inch)	1/2.6"		
焦距 Focal-Length	3.5mm		
後焦距 Back Focal-Length	4.75mm		
通光量 Aperture(D/F)	F2.8		
解析度 Pixel	3MP		
介面 Mount	M12×0.5P		
視場角Field of View	H		81.8°
	V		65.8°
	D		96°
畸變 Distortion	-0.70%		
尺寸 Dimension	Φ14*18.39mm		
鏡頭結構 Lens Construction	2G2P+IR 650		
重量 Weight	5g		
操作溫度 Operating Temperature	-10℃~+70℃		

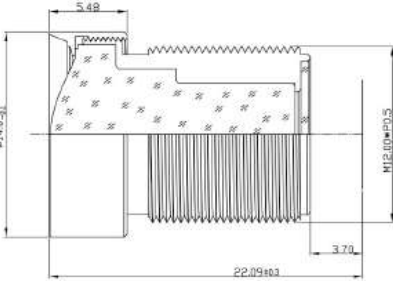
尺寸Size		公差Tolerance	
		尺寸Dimension	公差Tolerance
		0-10	±0.05
		10-30	±0.10
		30-120	±0.20

AMSL Lens

Hong Kong Office Address:
701, 7/F, TOWER 2, SILVERCORD, 30 CANTON ROAD, TSIM SHA TSUI, KOWLOON
Mandarin Factory Address:
#47, ROAD SHI YANG, HU MEN TOWN, CITY DONG GUAN, PROVINCE GUANG DONG, 523900
PHONE: +852 6672 1979/+86 185 2016 9694
WEBSITE: www.amsl-lens.biz

AMSL

Lens, 1/2.7"

Part #: 8049, M8, 3.2mm, 2MP, 16% Distortion, IP67

鏡頭參數 Parameter of Lens		圖片Photo (Just for Reference)	
型號 Model No	8049		
像面尺寸 Format(inch)	1/2.7"		
焦距 Focal-Length	3.2mm		
後焦距 Back Focal-Length	4.9mm		
通光量 Aperture(D/F)	F2.5		
解析度 Pixel	2MP		
螺紋螺距 Mount	M8×0.5P		
視場角Field of View	H		110°
	V		84°
	D		140°
畸變 Distortion	<-16%		
尺寸 Dimension	Φ10*10.95mm		
鏡頭結構 Lens Construction	4G+R 650		
重量 Weight	2g		
操作溫度 Operating Temperature	-10℃~+70℃		
防水等級 Waterproof Rating	IP67		

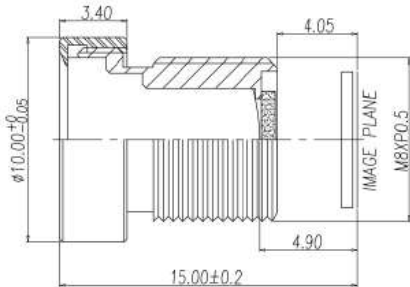
尺寸Size		公差Tolerance	
		尺寸Dimension	公差Tolerance
	0-10	±0.05	
	10-30	±0.10	
	30-120	±0.20	

AMSL Lens

Hong Kong Office Address:
701, 7/F, TOWER 2, SILVERCORD, 30 CANTON ROAD, TSIM SHA TSUI, KOWLOON
Mandrin Factory Address:
#47, ROAD SHI YANG, HU MEN TOWN, CITY DONG GUAN, PROVINCE GUANG DONG, 523900

PHONE: +852 6672 1979/+86 185 2016 9594
WEBSITE: www.amslens.biz

AMSL

Part #: 8068, M8, 3mm, 3MP, No Distortion

鏡頭參數 Parameter of Lens		圖片 Photo (Just for Reference)	
型號 Model No	8068		
像面尺寸 Format(inch)	1/2.7"		
焦距 Focal-Length	3.0mm		
後焦距 Back Focal-Length	3.5mm		
通光量 Aperture(D/f)	F2.5		
解析度 Pixel	3MP		
螺紋螺距 Mount	M8×0.35P		
視場角 Field of View	H		86°
	V		55°
	D		95°
畸變 Distortion	1%		
尺寸 Dimension	Φ10*12.15mm		
鏡頭結構 Lens Construction	2G+2P+IR 650		
重量 Weight	4g		
操作溫度 Operating Temperature	-10℃~+70℃		
防水等級 Waterproof Rating	IP67		

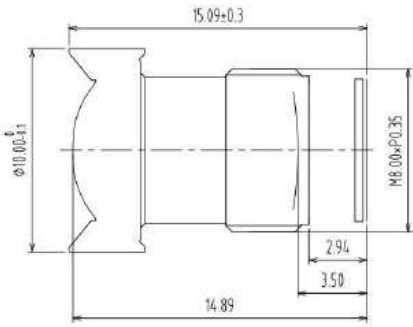
尺寸 Size		公差 Tolerance	
		尺寸 Dimension	公差 Tolerance
		0-10	±0.05
		10-30	±0.10
		30-120	±0.20

AMSL Lens

Hong Kong Office Address:
701, 7/F, TOWER 2, SILVERCORD, 30 CANTON ROAD, TSIM SHA TSUI, KOWLOON
Mandrin Factory Address:
#47, ROAD SHI YANG, HU MEN TOWN, CITY DONG GUAN, PROVINCE GUANG DONG, 523900
PHONE: +852 6672 1979/+86 185 2016 9594
WEBSITE: www.amsl-lens.biz



Part #: 8071, M12, 8mm, 2MP

鏡頭參數 Parameter of Lens		圖片 Photo (Just for Reference)	
型號 Model No	8071		
像面尺寸 Format(inch)	1/2.7"		
焦距 Focal-Length	8.0mm		
後焦距 Back Focal-Length	8.65mm		
通光量 Aperture(D/F)	F1.8		
解析度 Pixel	2MP		
介面 Mount	M12×0.5P		
視場角 Field of View	H		34.5°
	V		26°
	D		43°
畸變 Distortion	4%		
尺寸 Dimension	Φ14*13.90mm		
鏡頭結構 Lens Construction	4G		
重量 Weight	5g		
操作溫度 Operating Temperature	-10℃~+70℃		

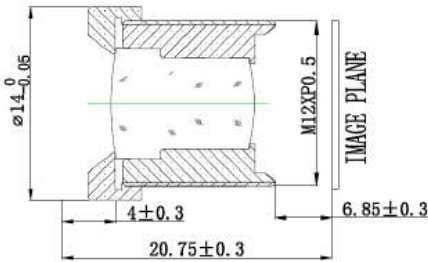
尺寸 Size		公差 Tolerance	
		尺寸 Dimension	公差 Tolerance
		0-10	±0.05
		10-30	±0.10
		30-120	±0.20

AMSL Lens

Hong Kong Office Address:
751, 7/F, TOWER 2, SILVERCORD, 30 CANTON ROAD, TSIM SHA TSUI, KOWLOON
Main Factory Address:
#47, ROAD SHI YANG, HU MEN TOWN, CITY DONG GUAN, PROVINCE GUANG DONG, 523900
PHONE: +852 6672 1979/+86 185 2016 9694
WEBSITE: www.amslens.biz

AMSL

Part #: 8072, M12, 6mm, 3MP

鏡頭參數 Parameter of Lens		圖片Photo (Just for Reference)	
型號 Model No	8072		
像面尺寸 Format(inch)	1/2.7"		
焦距 Focal-Length	6.0mm		
後焦距 Back Focal-Length	6.7mm		
通光量 Aperture(D/F)	F2.0		
解析度 Pixel	2MP		
介面 Mount	M12×0.5P		
視場角Field of View	H		45°
	V		30°
	D		60°
尺寸 Dimension	Φ14*16.33mm		
鏡頭結構 Lens Construction	4G		
重量 Weight	5g		
操作溫度 Operating Temperature	-20℃~+80℃		

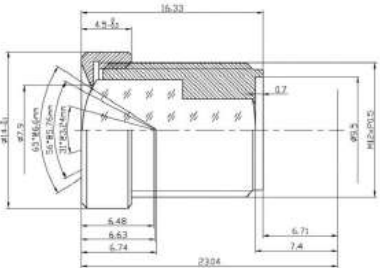
尺寸Size		公差Tolerance	
		尺寸Dimension	公差Tolerance
		0-10	±0.05
		10-30	±0.10
		30-120	±0.20

AMSL Lens

Hong Kong Office Address:
701, 7/F, TOWER 2, SILVERCOORD, 30 CANTON ROAD, TSIM SHA TSUI, KOWLOON

Mandrin Factory Address:
#47, ROAD SHI YANG, HU MEN TOWN, CITY DONG GUAN, PROVINCE GUANG DONG, 523900

PHONE: +852 6672 1979/+86 185 2016 5694
WEBSITE: www.amsl-lens.biz



Lens, 1/2.9"

Part #: 8075, M12, 2.1mm, 2MP, 35% Distortion

鏡頭參數 Parameter of Lens		圖片 Photo (Just for Reference)	
型號 Model No	8075		
像面尺寸 Format(inch)	1/2.9"		
焦距 Focal-Length	2.1mm		
後焦距 Back Focal-Length	2.6mm		
透光量 Aperture(D/F)	F2.0		
解析度 Pixel	2MP		
介面 Mount	M12×0.5P		
視場角 Field of View	H		140°
	V		85°
	D		160°
尺寸 Dimension	Φ14*12.3mm		
畸變 Distortion	<-35%		
鏡頭結構 Lens Construction	4G+1 IR(optional)		
重量 Weight	4g		
操作溫度 Operating Temperature	-20℃~+80℃		

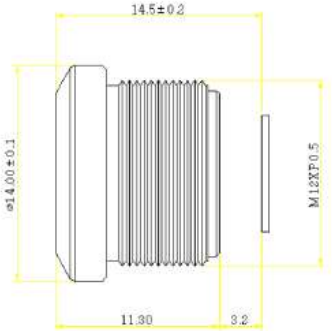
尺寸 Size		公差 Tolerance	
		尺寸 Dimension	公差 Tolerance
		0-10	±0.05
		10-30	±0.10
		30-120	±0.20

AMSL Lens

Hong Kong Office Address:
7D1, 7/F, TOWER 2, SILVERCORD, 30 CANTON ROAD, TSIM SHA TSUI, KOWLOON
Mandarin Factory Address:
#47, ROAD SHI YANG, HU MEN TOWN, CITY DONG GUAN, PROVINCE GUANG DONG, 523900
PHONE: +852 6672 1979/+86 185 2016 9694
WEBSITE: www.amsl-lens.biz



Part #: 8076, M12, 2.4mm, 3MP

鏡頭參數 Parameter of Lens		圖片 Photo (Just for Reference)	
型號 Model No	8076		
像面尺寸 Format(inch)	1/2.9"		
焦距 Focal-Length	2.4mm		
後焦距 Back Focal-Length	3.2mm		
通光量 Aperture(D/F)	F2.0		
解析度 Pixel	3MP		
介面 Mount	M12×0.5P		
視場角 Field of View	H		95°
	V		55°
	D		115°
尺寸 Dimension	Φ14*12.75mm		
畸變 Distortion	<-0.1%		
鏡頭結構 Lens Construction	5E+1 IR(optional)		
重量 Weight	2.2g		
操作溫度 Operating Temperature	-20℃~+80℃		

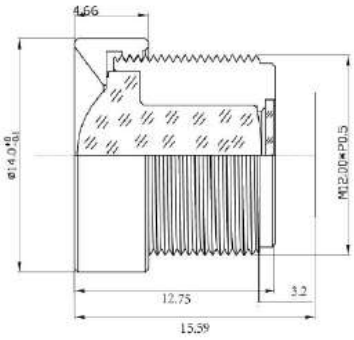
尺寸 Size		公差 Tolerance	
		尺寸 Dimension	公差 Tolerance
		0-10	±0.05
		10-30	±0.10
		30-120	±0.20

AMSL Lens

Hong Kong Office Address:
 701, 7/F, TOWER 2, SILVERCORD, 30 CANTON ROAD, TSIM SHA TSUI, KOWLOON
 Mandarin Factory Address:
 #47, ROAD SHI YANG, HU MEN TOWN, CITY DONG GUAN, PROVINCE GUANG DONG, 523900
 PHONE: +852 6672 1979/+86 185 2016 9594
 WEBSITE: www.amsl-lens.biz



Part #: 8077, M12, 4.4mm, 2MP

鏡頭參數 Parameter of Lens		圖片Photo (Just for Reference)	
型號 Model No	8077		
像面尺寸 Format(inch)	1/2.9"		
焦距 Focal-Length	4.4mm		
後焦距 Back Focal-Length	3.43mm		
通光量 Aperture(D/P)	F2.0		
解析度 Pixel	2MP		
介面 Mount	M12×0.5P		
視場角Field of View	H		70°
	V		40°
	D		81°
尺寸 Dimension	Φ14*10.9mm		
鏡頭結構 Lens Construction	1G+3P+1 IR(optional)		
重量 Weight	5g		
操作溫度 Operating Temperature	-20℃ ~ +80℃		

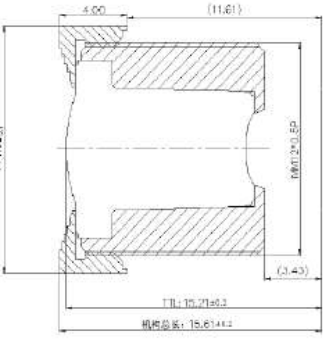
尺寸Size		公差Tolerance	
		尺寸Dimension	公差Tolerance
		0-10	±0.05
		10-30	±0.10
		30-120	±0.20

AMSL Lens

Hong Kong Office Address:
701, 7/F, TOWER 2, SILVERCORD, 30 CANTON ROAD, TSIM SHA TSUI, KOWLOON
Mandarin Factory Address:
#47, ROAD SHI YANG, HU MEN TOWN, CITY DONG GUAN, PROVINCE GUANG DONG, 523900
PHONE: +852 6672 1979/+86 185 2016 9594
WEBSITE: www.amsl-lens.biz

AMSL

Lens, 1/3”

Part #: 8053, CS, 2.8mm, 5MP, 22% Distortion

鏡頭參數 Parameter of Lens		圖片 Photo (Just for Reference)	
型號 Model No	8053		
像面尺寸 Format(inch)	1/3"		
焦距 Focal-Length	2.8mm (Fixed)		
後焦距 Flange Back Length	6.9mm		
光學總長 Total Track Length	24.12mm		
通光量 Aperture(D/F)	F 2.0		
解析度 Pixel	5MP		
螺紋螺距 Mount	CS		
視場角 Field of View	D		120°
	H		92°
	V		67°
畸變 Distortion	<22%		
尺寸 Dimension	Φ28*17.4mm		
鏡頭結構 Lens Construction	4G		
重量 Weight	20g		
操作溫度 Operating Temperature	-10℃~+70℃		

尺寸 Size		公差 Tolerance	
		尺寸 Dimension	公差 Tolerance
		0-10	±0.05
		10-30	±0.20
30-120	±0.20		

AMSL Lens

Hong Kong Office Address:
701, 7/F, TOWER 2, SILVERCORD, 30 CANTON ROAD, TSIM SHA TSUI, KOWLOON
Mandrin Factory Address:
#47, ROAD SHI YANG, HU MEN TOWN, CITY DONG GUAN, PROVINCE GUANG DONG, 523900
PHONE: +852 6672 1979/+86 185 2016 6694
WEBSITE: www.ams-lens.biz

Part #: 8055, M6, 4.3mm, 3MP, 1% Distortion

鏡頭參數 Parameter of Lens		圖片 Photo (Just for Reference)	
型號 Model No	8055		
像面尺寸 Format(inch)	1/3"		
焦距 Focal-Length	4.3mm		
後焦距 Flange Back Length	1.0mm		
光學總長 Total Track Length	5.5mm		
通光量 Aperture(D/F)	F2.4		
解析度 Pixel	5MP		
螺紋螺距 Mount	M6.5x0.25P		
視場角Field of View	D		65°
	H		52°
	V		40°
畸變 Distortion	<-1%		
尺寸 Dimension	Φ6.5mm*4.5mm		
鏡頭結構 Lens Construction	5P+IR 650		
操作溫度 Operating Temperature	-10℃~+70℃		

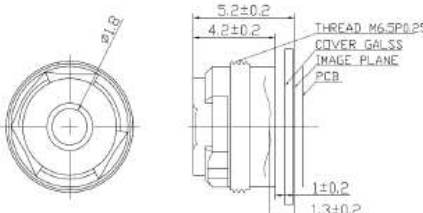
尺寸Size		公差Tolerance	
		尺寸Dimension	公差Tolerance
		0-10	±0.05
		10-30	±0.20
		30-120	±0.20

AMSL Lens

Hong Kong Office Address:
701, 7/F, TOWER 2, SILVERCORD, 30 CANTON ROAD, TSIM SHA TSUI, KOWLOON
Mandrin Factory Address:
#47, ROAD SHI YANG, HU MEN TOWN, CITY DONG GUAN, PROVINCE GUANG DONG, 523900
PHONE: +852 6672 1979/+86 185 2016 9594
WEBSITE: www.amslens.biz

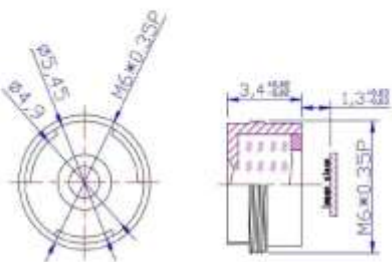

Part #: 8056, M6, 4.2mm, 3MP, 1% Distortion

鏡頭參數 Parameter of Lens		圖片 Photo (Just for Reference)	
型號 Model No	8056		
像面尺寸 Format(Inch)	1/3"		
焦距 Focal Length	4.2mm		
後焦距 Back Focal Length	1.3mm		
通光量 Aperture(DiF)	F2.2		
解析度 Pixel	4MP		
螺紋螺絲 Mount	M6×0.35P		
視場角 Field of View	D 68°		
畸變 Distortion	<-1%		
尺寸 Dimension	Φ5.45mm*3.4mm		
鏡頭結構 Lens Construction	4P+IR 650		
重量 Weight	2g		
操作溫度 Operating Temperature	-10℃ ~ +70℃		
尺寸 Size			公差 Tolerance
		尺寸 Dimension 公差 Tolerance	
		0-10	±0.05
		10-30	±0.20
		30-120	±0.20
AMSL Lens Hong Kong Office Address: 731, 7/F, TOWER 2, SILVERCORD, 38 CANTON ROAD, Tsim Sha Tsui, Kowloon Mainland Factory Address: #47, ROAD SHI YANG, HU MEN TOWN, CITY DONG GUANG PROVINCE GUANG DONG, 523905 PHONE: +86 6672 1875/+86 166 2018 9594 WEBSITE: www.amsl-ey.com			
			

Part #: 8057, M7, 1.9mm, 2MP, 26% Distortion

鏡頭參數 Parameter of Lens		圖片Photo (Just for Reference)	
型號 Model No	8057		
像面尺寸 Format(Inch)	1/3"		
焦距 Focal-Length	1.9mm		
後焦距 Back Focal-Length	3.52mm		
通光量 Aperture(D/F)	F2.0		
解析度 Pixel	2MP		
螺紋規格 Mount	M7×0.35P		
視場角Field of View	H		120°
	V		100°
	D		160°
畸變 Distortion	26%		
尺寸 Dimension	Φ10mm*8.58mm		
鏡頭結構 Lens Construction	5E+IR 650		
重量 Weight	6g		
操作溫度 Operating Temperature	-10℃ ~ +70℃		
尺寸Size		公差Tolerance	
		尺寸Dimension公差Tolerance	
		0-10	±0.05
		10-30	±0.20
		30-120	±0.20
AMSL Lens Hong Kong Office Address: T01, 7/F, TOWER 2, SILVERCORD, 30 CANTON ROAD, TSM SHA TSU, KOWLOON Mainland Factory Address: #NT, ROAD SHI YANG, HU MEN TOWN, CITY DONG GUAN, PROVINCE GUANG DONG, 523800 PHONE: +852 0672 1979#381 185 2016 2584 WEBSITE: www.amsl-lens.biz			

Part #: 8074, M12, 3.2mm, 2MP, 23% Distortion

鏡頭參數 Parameter of Lens		圖片 Photo (Just for Reference)	
型號 Model No	8074		
像面尺寸 Format(inch)	1/3"		
測試芯片 Referred Sensor	1/3" OV4689		
	2668*1520 2.0um		
焦距 Focal-Length	3.2mm		
後焦距 Back Focal-Length	6.92mm		
通光量 Aperture(D/F)	F1.7		
解析度 Pixel	200LP/mm on center		
介面 Mount	M12*0.5P		
視場角Field of View	H		99°
	V		55°
	D		115°
尺寸 Dimension	Φ17.5*17.09mm		
畸變 Distortion	<-23%		
鏡頭結構 Lens Construction	6G+1 IR(optional)		
重量 Weight	6.5g		
操作溫度 Operating Temperature	-20℃~+80℃		

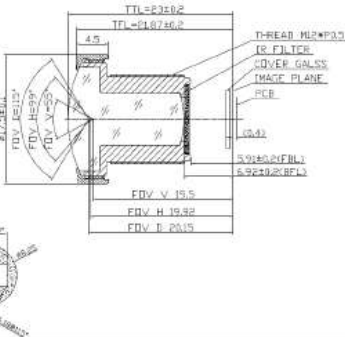
尺寸 Size		公差 Tolerance	
		尺寸 Dimension	公差 Tolerance
		0-10	±0.05
		10-30	±0.10
		30-120	±0.20

AMSL Lens

Hong Kong Office Address:
701, 7/F, TOWER 2, SILVERCORD, 30 CANTON ROAD, TSIM SHA TSUI, KOWLOON
Mandrin Factory Address:
#47, ROAD SHI YANG, HU MEN TOWN, CITY DONG GUAN, PROVINCE GUANG DONG, 523900
PHONE: +852 6672 1979/+86 195 2016 9594
WEBSITE: www.amsl-lens.biz

AMSL

Part #: 8097, M12, 2.8mm, 5MP, 1% Distortion

鏡頭參數 Parameter of Lens		圖片 Photo (Just for Reference)	
型號 Model No	8097		
像面尺寸 Format(inch)	1/3"		
焦距 Focal-Length	2.8mm		
後焦距 Back Focal-Length	2.85mm		
光學總長 Total Track Length	15.6mm		
通光量 Aperture(D/F)	F2.8		
解析度 Pixel	5MP		
螺紋螺距 Mount	M12×0.5P		
視場角 Field of View	H		98°
	V		82°
	D		125°
畸變 Distortion	<1%		
尺寸 Dimension	Φ14*15.6mm		
鏡頭結構 Lens Construction	4G		
重量 Weight	3g		
操作溫度 Operating Temperature	-10℃~+70℃		



尺寸 Size		公差 Tolerance	
		尺寸 Dimension	公差 Tolerance
		0-10	±0.05
		10-30	±0.10
		30-120	±0.20

AMSL Lens

Hong Kong Office Address:
701, 7/F, TOWER 2, SILVERCORD, 30 CANTON ROAD, TSIM SHA TSUI, KOWLOON
Mandrin Factory Address:
#47, ROAD SHI YANG, HU MEN TOWN, CITY DONG GUAN, PROVINCE GUANG DONG, 523900
PHONE: +852 6672 1979/+86 185 2016 9594
WEBSITE: www.amsl-lens-cam.biz





Lens, 1/4"

Part #: 8048, M8, 2.6mm, 2MP, 10.7% Distortion

鏡頭參數 Parameter of Lens		圖片 Photo (Just for Reference)	
型號 Model No	8048		
像面尺寸 Format(inch)	1/4"		
焦距 Focal-Length	2.6mm		
後焦距 Back Focal-Length	3.0mm		
通光量 Aperture(Di#)	F2.4		
解析度 Pixel	2MP		
螺紋螺距 Mount	M8×0.5P		
視場角 Field of View	H		100°
	V		87°
	D		130°
畸變 Distortion	11%		
尺寸 Dimension	Φ10*7.4mm		
鏡頭結構 Lens Construction	2P+2G+1R 650		
重量 Weight	2g		
操作溫度 Operating Temperature	-10℃~+70℃		
尺寸 Size		公差 Tolerance	
		尺寸 Dimension	公差 Tolerance
		0-10	±0.05
		10-30	±0.10
		30-120	±0.20
<p>AMSL Lens</p> <p>Hong Kong Office Address: 721, 7/F, TOWER 2, SILVERCORD, 30 CANTON ROAD, TSIM SHA TSUI, KOWLOON</p> <p>Mandrin Factory Address: #47, ROAD SHI YANG, HU MEN TOWN, CITY DONG GUAN, PROVINCE GUANG DONG, 523900</p> <p>PHONE: +852 6672 1979/+86 185 2016 9594 WEBSITE: www.amslens.biz</p>			

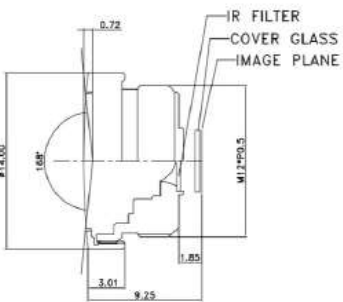
Part #: 8058, M12, 0.88mm, 2MP, 19% Distortion

鏡頭參數 Parameter of Lens		圖片 Photo (Just for Reference)	
型號 Model No	8058		
像面尺寸 Format(inch)	1/4"		
焦距 Focal-Length	0.88mm		
後焦距 Back Focal-Length	2.15mm		
透光量 Aperture(D/F)	F2.2		
解析度 Pixel	2MP		
螺紋螺距 Mount	M12×0.5P		
視場角 Field of View	H		136°
	V		110°
	D		168°
畸變 Distortion	19%		
尺寸 Dimension	Φ14*7.4mm		
鏡頭結構 Lens Construction	3E+R 650		
重量 Weight	3g		
操作溫度 Operating Temperature	-10℃~+70℃		
尺寸 Size		公差 Tolerance	
		尺寸 Dimension	公差 Tolerance
		0-10	±0.05
10-30	±0.10		
30-120	±0.20		
<p>AMSL Lens</p> <p>Hong Kong Office Address: 701, 7/F, TOWER 2, SILVERCORD, 30 CANTON ROAD, TSIM SHA TSUI, KOWLOON</p> <p>Mandrin Factory Address: #47, ROAD SHI YANG, HU MEN TOWN, CITY DONG GUAN, PROVINCE GUANG DONG, 523900</p> <p>PHONE: +852 6672 1979/+86 185 2016 9594 WEBSITE: www.amsl-hens.biz</p>			

Part #: 8060, M7, 2.07mm, 5MP, 8.5% Distortion

鏡頭參數 Parameter of Lens		圖片 Photo (Just for Reference)	
型號 Model No	8060		
像面尺寸 Format(inch)	1/4"		
焦距 Focal-Length	2.07mm		
後焦距 Back Focal-Length	2.49mm		
通光量 Aperture(D/F)	F2.6		
解析度 Pixel	3MP		
螺紋螺距 Mount	M7×0.35P		
視場角 Field of View	H		95°
	V		63°
	D		109°
畸變 Distortion	9%		
尺寸 Dimension	Φ10*9.31mm		
鏡頭結構 Lens Construction	4P+IR 650		
重量 Weight	1g		
操作溫度 Operating Temperature	-10℃~+70℃		

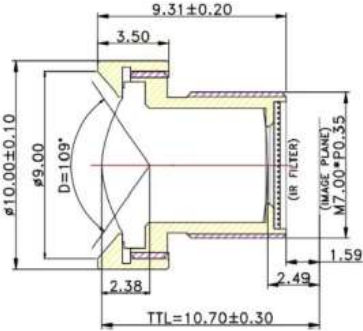
尺寸 Size		公差 Tolerance	
		尺寸 Dimension	公差 Tolerance
	0-10	±0.05	
	10-30	±0.10	
	30-120	±0.20	

AMSL Lens

Hong Kong Office Address:
701, 7/F, TOWER 2, SILVERCORD, 30 CANTON ROAD, TSIM SHA TSUI, KOWLOON
Mandarin Factory Address:
#47, ROAD SHI YANG, HU MEN TOWN, CITY DONG GUAN, PROVINCE GUANG DONG, 523900
PHONE: +852 6672 1979/+86 185 2016 9594
WEBSITE: www.amsl-lens.biz

AMSL

Part #: 8061, M7.3, 2.2mm, 2MP, 16% Distortion

鏡頭參數 Parameter of Lens		圖片Photo (Just for Reference)	
型號 Model No	8061		
像面尺寸 Format(inch)	1/4"		
焦距 Focal-Length	2.2mm		
後焦距 Back Focal-Length	0.7mm		
通光量 Aperture(D/F)	F2.2		
解析度 Pixel	2MP		
螺紋螺距 Mount	M7.3×0.2P		
視場角Field of View	H		95°
	V		60°
	D		118°
畸變 Distortion	16%		
尺寸 Dimension	Φ10*10mm		
鏡頭結構 Lens Construction	5P+R 650		
重量 Weight	1g		
操作溫度 Operating Temperature	-10℃~+70℃		
尺寸Size		公差Tolerance	
		尺寸Dimension	公差Tolerance
		0-10	±0.05
		10-30	±0.10
30-120	±0.20		
AMSL Lens Hong Kong Office Address: 701, 7/F, TOWER 2, SILVERCORD, 30 CANTON ROAD, TSIM SHA TSUI, KOWLOON Mandrin Factory Address: #47, ROAD SHI YANG, HU MEN TOWN, CITY DONG GUAN, PROVINCE GUANG DONG, 523600 PHONE: +852 6672 1979/+86 185 2016 9594 WEBSITE: www.amsl-lens.biz			

Part #: 8063, M8, 2.23mm, 1.3MP, 13% Distortion, IP67

鏡頭參數 Parameter of Lens		圖片Photo (Just for Reference)	
型號 Model No	8063		
像面尺寸 Format(inch)	1/4"		
焦距 Focal-Length	2.23mm		
後焦距 Back Focal-Length	1.99mm		
通光量 Aperture(D/F)	F2.2		
解析度 Pixel	1.3MP		
螺紋螺距 Mount	M8×0.5P		
視場角Field of View	H		90°
	V		60°
	D		110°
畸變 Distortion	13%		
尺寸 Dimension	Φ12*11.19mm		
鏡頭結構 Lens Construction	3G+1P+IR 650		
重量 Weight	3g		
操作溫度 Operating Temperature	-10℃~+70℃		
防水等級 Waterproof Rating	IP67		



尺寸Size		公差Tolerance	
		尺寸Dimension	公差Tolerance
		0-10	±0.05
		10-30	±0.10
		30-120	±0.20

AMSL Lens

Hong Kong Office Address:
701, 7/F, TOWER 2, SILVERCORD, 30 CANTON ROAD, TSIM SHA TSUI, KOWLOON
Mandrin Factory Address:
#47, ROAD SHI YANG, HU MEN TOWN, CITY DONG GUAN, PROVINCE GUANG DONG, 523900

PHONE: +852 6672 1979/+86 185 2016 9594
WEBSITE: www.amslens.biz

AMSL

Part #: 8064, M8, 1.9mm, 2MP, 25% Distortion, IP67

鏡頭參數 Parameter of Lens		圖片 Photo (Just for Reference)	
型號 Model No	8064		
像面尺寸 Format(inch)	1/4"		
焦距 Focal-Length	1.9mm		
後焦距 Back Focal-Length	3.0mm		
通光量 Aperture(D/F)	F2.2		
解析度 Pixel	2MP		
螺紋螺距 Mount	M8×0.5P		
視場角 Field of View	H		112°
	V		65°
	D		125°
畸變 Distortion	25%		
尺寸 Dimension	Φ12*10.54mm		
鏡頭結構 Lens Construction	2G+4P+IR 650		
重量 Weight	4g		
操作溫度 Operating Temperature	-10℃~+70℃		
防水等級 Waterproof Rating	IP67		

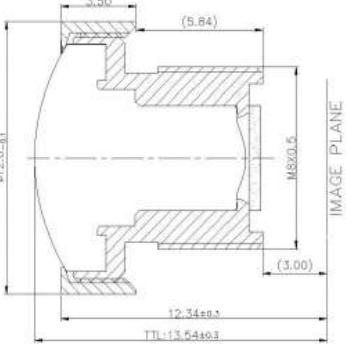
尺寸 Size		公差 Tolerance	
		尺寸 Dimension	公差 Tolerance
		0-10	±0.05
		10-30	±0.10
		30-120	±0.20

AMSL Lens

Hong Kong Office Address:
701, 7/F, TOWER 2, SILVERCORD, 30 CANTON ROAD, TSIM SHA TSUI, KOWLOON
Mandarin Factory Address:
#47, ROAD SHI YANG, HU MEN TOWN, CITY DONG GUAN, PROVINCE GUANG DONG, 523900
PHONE: +852 6672 1979/+86 185 2016 9694
WEBSITE: www.amsl-lens.biz

AMSL

Lens, 1/6"

Part #: 8052, M5.5, 3.15mm, 2MP

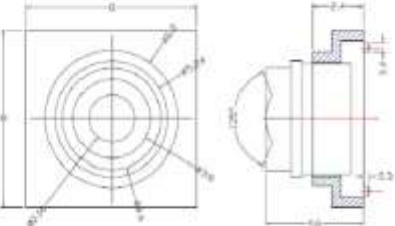
鏡頭參數 Parameter of Lens		圖片 Photo (Just for Reference)	
型號 Model No	8052		
像面尺寸 Format(inch)	1/6"		
焦距 Focal-Length	3.15mm		
物距 FOCUS	>30mm		
後焦距 Back Focal-Length	0.75mm		
透光量 Aperture(DiF)	F2.4		
解析度 Pixel	2MP		
介面 Mount	M5.5×0.25P		
畸變 Distortion	<5%		
視場角 Field of View	H		76°
	V		57°
	D		95°
光學總長 TTL	4.1mm		
尺寸 Dimension	Φ5.7×3.3mm		
鏡頭結構 Lens Construction	4 Plastic +1IR		
尺寸 Size			
	公差 Tolerance		
	尺寸 Dimension	公差 Tolerance	
	X _{XX}	±0.02	
X _X	±0.05		
X _{...}	±0.10		
<p>AMSL Lens</p> <p>Hong Kong Office Address: WU WAH FACTORY BUILDING, 2/F, NO.41 WING HONG STREET, LAI CHI KOK Mandrin Factory Address: #47, ROAD SHE YANG, HU MEN TOWN, CITY DONG GUAN, PROVINCE GUANG DONG, 523600</p> <p>PHONE: +852 8672 9970/+86 185 2015 9554 WEBSITE: www.amsl-lens.com.hk</p>			

Part #: 8081, M6, 1.2mm, 2MP

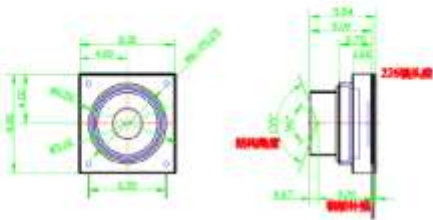
鏡頭參數 Parameter of Lens		圖片Photo (Just for Reference)	
型號 Model No	8081		
像面尺寸 Format(Inch)	1/5"		
焦距 Focal-Length	1.2mm		
物距 FOCUS	>30mm		
後焦距 Back Focal-Length	0.82mm		
透光量 Aperture(DiF)	F2.5		
解析度 Pixel	2MP		
介面 Mount	M6×0.25P		
畸變 Distortion	<-3.2%		
視場角Field of View	H		82°
	V		68°
	D		100°
光學總長 TTL	5.54mm		
尺寸 Dimension	Φ6.4*4.0mm		
鏡頭結構 Lens Construction	5 Plastic +1IR		
尺寸Size			
	公差Tolerance		
	尺寸Dimension	公差Tolerance	
	X_XX	±0.02	
X_X	±0.05		
X_	±0.10		
<p>AMSL</p> <p>Hong Kong Office Address: 701, 7/F, TOWER 2, SILVERCORD, 30 CANTON ROAD, TSM SHA-TSUI, KOWLOON</p> <p>Mainland Factory Address: M47, ROAD SHE YANG, HU MEN TOWN, CITY DONG GUAN, PROVINCE GUANG DONG, 523600</p> <p>PHONE: +862 0672 1076/+86 185 2016 0504 WEBSITE: www.amsl-lens.biz</p>			

Part #: 8082, M5.7, 1.0mm, 2MP

鏡頭參數 Parameter of Lens		圖片 Photo (Just for Reference)
型號 Model No	8082	
像面尺寸 Format(Inch)	1/6"	
焦距 Focal-Length	1.0mm	
物距 FOCUS	>30mm	
後焦距 Back Focal-Length	0.9mm	
透光量 Aperture(D/F)	F2.8	
解析度 Pixel	VGA	
介面 Mount	M5.7x0.25P	
畸變 Distortion	<-1.5%	
視場角 Field of View	H	
	V	75°
	D	125°
光學總長 TTL	4.4mm	
尺寸 Dimension	Φ5.7*3.5mm	
鏡頭結構 Lens Construction	5 Plastic + 1IR	

尺寸 Size		公差 Tolerance	
		尺寸 Dimension	公差 Tolerance
	X_XX	±0.02	
	X_X	±0.05	
	X_	±0.10	

AMSL Lens

Hong Kong Office Address:
 18/F, WING FACTORY BUILDING, 3/F, NO.41 WING HONG STREET, LAI CHI KOK,
 Mandrin Factory Address:
 #47, ROAD SHI YANG, HUIMEN TOWN, CITY DONG GUAN, PROVINCE GUANG DONG, 522600

PHONE: +852 6672 1079/486 185 2010 9594
 WEBSITE: www.amsl-lens.com.hk

Lens, 1/10.5"

Part #: 8073, M3, 1.03mm, 1MP

鏡頭參數 Parameter of Lens		圖片 Photo (Just for Reference)		
型號 Model No	8073			
像面尺寸 Format(Inch)	1/10.5"			
焦距 Focal-Length	1.03mm			
物距 FOCUS	>20mm			
後焦距 Back Focal-Length	0.73mm			
透光量 Aperture(DiP)	F4.7			
解析度 Pixel	VGA			
介面 Mount	M3x0.3P			
畸變 Distortion	<-1.5%			
視場角Field of View	H			75°
	V			49°
	D			79°
光學總長 TTL	2.9mm			
尺寸 Dimension	Φ3.0*2.4mm			
鏡頭結構 Lens Construction	3 Plastic +1IR			
尺寸 Size			公差 Tolerance	
			尺寸 Dimension	公差 Tolerance
			X _{XX}	±0.02
			X _X	±0.05
X _—	±0.10			
<p>AMSL Lens</p> <p>Hong Kong Office Address: T01, 7/F, TOWER 2, SILVERCORD, 30 CANTON ROAD, TSM SHA TSUI, KOWLOON</p> <p>Nanshan Factory Address: B4T, ROAD SHI YANG, HU MEN TOWN, CITY DONG GUAN, PROVINCE GUANG DONG, 533002</p> <p>PHONE: +86 6672 1679-36 185 2016 9894 WEBSITE: www.amsl-hk.hk</p>				
				<p>31 / 59</p>

Camera Module, IMP

Part #: 8995, 1MP, GC1064+USB, 54x38

攝像頭參數 Parameter of Lens-Camera Module		圖片 Photo (Just for Reference)	
型號 Model No	8995		
圖像傳感 Image Sensor	GC1064		
圖像色彩 Image Color	RGB		
夜視功能 Night Vision	I-Cut 850nm LED		
分辨率 Pixel	1280 x 720P		
幀數 Frame Rate	1280x720P @30fps		
照相尺寸 Lens Type	1/4 inch		
對焦類型 Module Type	Fixed		
鏡頭 Lens	視角 View Angle		DFOV=125°
	鏡頭結構 Lens Construction		4E
	光學總長 Optical Length		22mm
	畸變 Distortion		TV < 20%
	焦距 Focus		2.6mm
電路板材質 PCB Material	FR4		
接口 Interface	USB 2.0		
輸出格式 Output	YUV2/MJPEG		
I-Cut 接口定義 Pins	1	IR+	
	2	IR-	
USB 接口定義 Pins	1	GND	
	2	DP	
	3	DM	
	4	SY	

更多圖片
More
Pictures

TOP VIEW

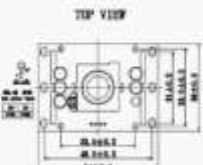

RIGHT VIEW



BOTTOM VIEW

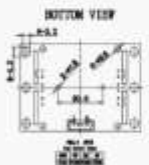

FRONT VIEW



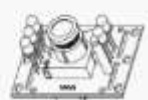

Lens parameter: 4E
DfL: 2.5mm
E: 80.2:4
View Angle: 125°, 200°, 150°
Distortion: 0.18%
Only Type: 1/4"
Apex Size: 80°
Thread Size: M2.0x0.4mm

REV	DATE	DESCRIPTION	BY	CHK	APP	DATE
01	1.10.18	NEW BY	WJG	WJG	WJG	10.18
02	1.10.18	REV BY	WJG	WJG	WJG	10.18
03	1.10.18	REV BY	WJG	WJG	WJG	10.18
04	1.10.18	REV BY	WJG	WJG	WJG	10.18
05	1.10.18	REV BY	WJG	WJG	WJG	10.18

Part #: 9009, 1MP, OV9726 + USB, 60x8, long shape

攝像頭參數 Parameter of Lens-Camera Module		圖片 Photo (Just for Reference)
型號 Model No	9009	
電路圖設計編號 PCB Layout No	V44-5PN	
圖像傳感 Image Sensor	OV9726	
分辨率 Resolution	1MP	
分辨率 Pixel	1200x800	
相面尺寸 Lens Type	1/6.5 inch	
對焦類型 Module Type	Fixed	
視角 View Angle	65°	
鏡頭結構 Lens Construction	3P	
鏡頭光圈 Lens FNo	2.8	
焦距 Lens ELF	2.8 mm	
紅外線光片 IR Filter	650 nm	
整體尺寸 Overall Size	60x8x3.35 mm	
電路板材質 PCB Material	FR4 + Steel Reinforce	
電路板顏色 PCB Color	Yellow	
接口 Interface	USB 2.0	
輸出格式 Output	YUY2/MJPEG	
接口定義 Pins	1	VCC_5v
	2	D-
	3	D+
	4	GND
	5	GND

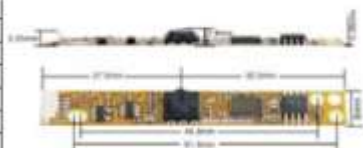

	TOP VIEW	SIDE VIEW	BOTTOM VIEW
更多圖片 More Pictures			

Part #: 9024, 1MP, H62 + USB, 38x38

參數 Parameter		圖片 Photo (Just for Reference)
型號 Model No	9024	
傳感器規格 Image Device	1/4" CMOS	
感光芯片 Chip	H62	
圖像制式 Output Type	MJPEG/ YUY2	
像素尺寸 Cell Size	3um x 3um	
解析度 Pixel	1MP	
最大分辨率 Max Resolution	1280(H)X720(V)	
鏡頭類型 Lens Focus	Fixed	
最低亮度 Sensitivity	0.051 Lux @ F2.2	
白平衡 AEC/Gain/White Balance	Auto	
幀率 Image Transfer Rate (MJPEG)	840*480 YUV2@25fps	
	1280*720 MJPEG@30fps	
接口類型 Interface	USB 2.0 High Speed	
驅動協議 Driver Implement	USB Video Class	
操作系統 Compatible OS	Windows, Android, IOS	
電壓 Power Supply	DC 5V	
工作電流 Consumption Current	160mA	
尺寸 Dimensions	38x38mm/32x32mm	
重量 Weight	Approx. 30g	
AMSL Lens Hong Kong Office Address: 751, 7/F, TOWER 2, SILVERCORD, 30 CANTON ROAD, TSM SHA TSUI, KOWLOON Mainland Factory Address: #47, ROAD SHI YANG, HU MEN TOWN, CITY DONG GUAN, PROVINCE GUANG DONG, 523800 PHONE: +852 6672 1676-88 182 2016 6594 WEBSITE: www.amsl-lens.biz		

Camera Module, 2MP

Part #: 8986, 2MP, GC2053 + CVBS, 14 Dia, FPV

參數 Parameter		圖片 Photo (Just for Reference)
型號 Model No	8986	
傳感器規格 Image Device	1/2.9" CMOS	
圖像傳感器 Image Sensor	GC2053	
圖像處理器 Image Signal Processor	FH8536H	
視頻標準 Video Type	CVBS	
視頻制式 TV Type	PAL	
快門速度 PAL Shutter	1/25~1/10,000 Sec	
有效像素 Effective Pixels	1920H x 1080V	
像素尺寸 Cell Size	2.8um x 2.8um	
水平解析度 Horizontal Resolution	1,200 TV Lines	
同步方式 Sync. Type	Internal	
幀率 Image Transfer Rate	1080P @30fps	
白平衡 Gain Control Gain	Auto Auto	
電壓 Power Supply	3.3V	
鏡頭類型 Lens Mount	Fixed	
尺寸 Dimensions	14mm in diameter	
重量 Weight	Approx. 5g	

AMSL Lens

Hong Kong Office Address:
701, 7/F, TOWER 2, SILVERCORD, 30 CANTON ROAD, TSIM SHA TSUI, KOWLOON

Mainland Factory Address:
#47, ROAD SHI YANG, HUIMEN TOWN, CITY DONG GUAN, PROVINCE GUANG DONG, 523900

PHONE: +852 6672 1979+86 185 2916 9594
WEBSITE: www.amsl-lens.biz



Part #: 9012, 2MP, OV2640 + MIPI, FPC, 120 Degree

攝像頭參數 Parameter of Lens-Camera Module		圖片 Photo (Just for Reference)	
型號 Model No	9012		
圖像傳感 Image Sensor	OV2640		
分辨率 Resolution	2MP		
分辨率 Pixel	1600x1200		
視角 View Angle	120°		
相面尺寸 Lens Type	1/4 inch		
對角類型 Module Type	Fixed		
大體尺寸 Overall Size	12.5x21.0x12.4mm		
大體重量 Overall Weight	15g		
接口 Interface			
引腳 Pins	#1		NC
	#2		AGND
	#3		SDA
	#4		AVDD 2.8V
	#5		SCL
	#6		RESET
	#7		VS
	#8		PWDN
	#9		HS
	#10		DVDD 1.2V
	#11		DOVDD 2.8V
	#12		D9
	#13		MCLK
	#14		D8
	#15		DGND
	#16		D7
	#17		PCLK
	#18		D6
	#19		D2
	#20		D5
	#21		D3
	#22		D4
	#23		D1
	#24	D0	

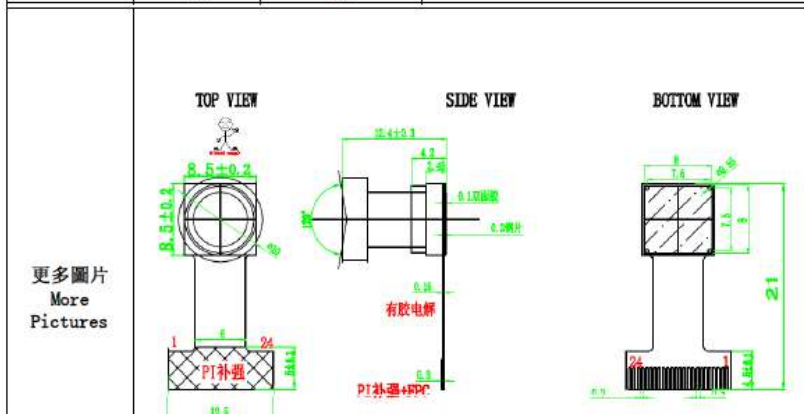

Part #: 9022, 2MP, OS02G10 + MIPI, FPC

攝像頭參數 Parameter of Lens-Camera Module		圖片 Photo (Just for Reference)	
型號 Model No	9022	<p>Technical drawing showing a cross-section of the camera module. Dimensions include: total width 21.3±0.3, lens diameter 8.1±0.1, sensor diameter 18.5±0.1, sensor thickness 4.02±0.1, sensor to FPC distance 3.5±0.1, lens to sensor distance 0.4±0.05 (lens thickness), FPC thickness 0.12±0.03, and total height 0.3±0.05 (FPC).</p>	
圖像傳感 Image Sensor	OV OS02G10		
有效焦距 EFL	4.04mm		
通光量 F.NO	2.56		
分辨率 Pixel	1920 x 1080		
視角 View Angle	98°		
相面尺寸 Lens Type	1/2.9 inch		
對焦類型 Module Type	Fixed Focus		
接口 Interface	MIPI		
引腳 Pins	#1		AVDD 2.8V
	#2		AVDD 2.8V
	#3		RESET
	#4		DGND
	#5		MDP
	#6		MDN
	#7		DGND
	#8		NC
	#9		NC
	#10		DGND
	#11		DOVDD 18V
	#12		DOVDD 18V
	#13		DGND
	#14		NC
	#15		NC
	#16	DGND	
	#17	MCN	
	#18	MCP	
	#19	DGND	
	#20	MCLK	
	#21	NC	
	#22	SCL	
	#23	SDA	
	#24	DGND	



更多圖片 More Pictures	
<p>Technical drawing showing the top view of the camera module. Dimensions include: total width 13.65±0.1, lens diameter 13±0.1, sensor diameter 13±0.1, sensor thickness 4.5±0.1, and total height 12.5±0.1. A red 'PI' label is present on the bottom surface.</p>	<p>Technical drawing showing the front view of the camera module. Dimensions include: total width 18, sensor diameter 12.3, sensor thickness 4.5±0.1, and total height 12.3. A red '銅片' label is present on the top surface. The bottom surface shows a red '24' label and dimensions 0.25, 0.5, and 11.5.</p>

Part #: 9027, 2MP, SC2335 + CVBS, 32x32, 3.3v

參數 Parameter		圖片 Photo (Just for Reference)
型號 Model No	9027	
感測器規格 Image Device	1/3" CMOS	
影像传感器 Image Sensor	F37P/ SC2335	
圖像處理器 Image Signal Processor	XM330V300	
視頻標準 Video Type	CVBS	
視頻制式 TV Type	PAL	
有效像素 Effective Pixels	1920H x 1080V	
像素尺寸 Cell Size	3.75um x 3.75um	
水平解析度 Horizontal Resolution	>700 TV Lines	
同步方式 Sync. Type	Internal	
幀率 Image Transfer Rate	1080P @25fps	
	720P @25fps	
最低亮度 Sensitivity	0.01 Lux @ F1.2	
白平衡 Gain Control Gain	Auto Auto	
電壓 Power Supply	3.3V	
工作電流 Consumption Current	Max 50mA	
鏡頭類型 Lens Mount	Fixed	
尺寸 Dimensions	32mm x 32mm	
重量 Weight	Approx. 25g	
AMSL Lens Hong Kong Office Address: 701, 7/F, TOWER 2, SILVERCORD, 30 CANTON ROAD, TSM SHA TSUI, KOWLOON Mainland Factory Address: #47, HIGAO SHE YANG, HU MEI TOWN, CITY DONG GUAN, PROVINCE GUANG DONG, 523600 PHONE: +852 9672 9379/+86 185 2016 9594 WEBSITE: www.amsl-lens.biz		

Camera Module, 4MP

Part #: 8977, 4MP, OV4689 + MIPI, 38x38

攝像頭參數 Parameter of Lens-Camera Module		圖片Photo (Just for Reference)	
型號 Model No	8977	 	
圖像傳感 Image Sensor	OV4689-H67A		
分辨率 Resolution	4 MP		
分辨率 Pixel	2688*1520		
相面尺寸 Lens Type	1/3"		
電路板大小 Board Dimension	38x38 cm		
接口類型 Connector	FPC-0.5MM-42PIN		
接口 Interface	MIPI		
引腳 Pins	#1		IRCOU11
	#2		IRCOU12
	#3		IR_ON/OFF
	#4		SENSOR_RSTN
	#5		NC
	#6		NC
	#7		SPI0_MOSI/I2C0_SDA
	#8		SPI0_CLK/I2C0_SCL
	#9		GND
	#10		NC
	#11		NC
	#12		NC
	#13	NC	
	#14	GND	
	#15	NC	
	#16	NC	
	#17	NC	
	#18	NC	
	#19	GND	
	#20	MIPI0_D2PVI_DAT7	
	#21	MIPI0_D2MVI_DAT6	
	#22	MIPI0_CRPVI_DAT5	
#23	MIPI0_CRMVI_DAT4		
#24	GND		
#25	MIPI0_D3PVI_DAT3		
#26	MIPI0_D3MVI_DAT2		
#27	MIPI0_D0PVI_DAT1		
#28	MIPI0_D0MVI_DAT0		
#29	GND		
#30	MIPI0_D1MVI_HS		
#31	MIPI0_D1PVI_VS		
#32	GND		
#33	NC		
#34	NC		
#35	SENSOR_CLK		
#36	GND		
#37	VDD_1.8V		
#38	3.3V		
#39	3.3V		
#40	GND		
#41	VCC_12V		
#42	VCC_12V		

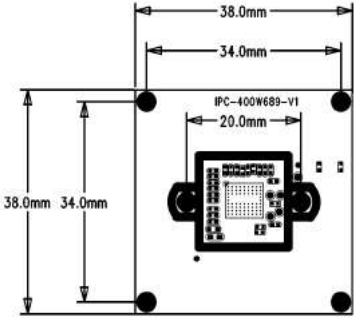

更多圖片 More Pictures	
--------------------------	---

Camera Module, 5MP

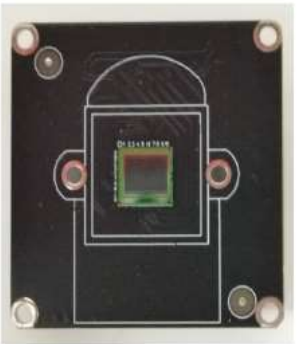
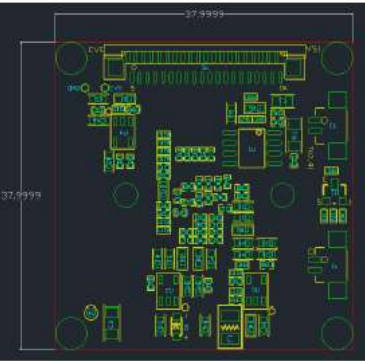
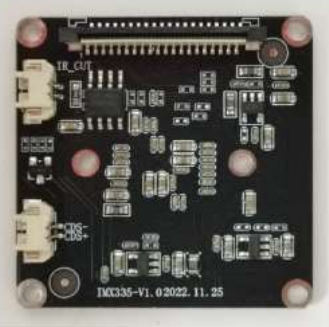
Part #: 8958, 5MP, IMX335 + MIPI, 38X38

攝像頭參數 Parameter of Lens-Camera Module		圖片Photo (Just for Reference)	
型號 Model No	8958		
圖像傳感 Image Sensor	IMX335		
分辨率 Resolution	5 MP		
分辨率 Pixel	2592*1944		
相面尺寸 Lens Type	1/2.7"		
電路板大小 Board Dimension	38x38 cm		
接口類型 Connector	XF3M-4015-1B		
接口 Interface	MIPI		
引腳 Pins	#1		12V
	#2		12V
	#3	DVDD_1.8V	
	#4	SR_RST	
	#5	C2B_INPUT	
	#6	ICR_ON	
	#7	ICR_OFF	
	#8	SR_MCK	
	#9	NC	
	#10	NC	
	#11	GND	
	#12	NC	
	#13	NC	
	#14	MD1P	
	#15	MD1N	
	#16	GND	
	#17	MCN	
	#18	MCP	
	#19	MD2N	
	#20	MD2P	
	#21	GND	
	#22	MD3N	
	#23	MD3N	
	#24	NC	
	#25	NC	
	#26	GND	
	#27	MD4P	
	#28	MD4N	
	#29	NC	
	#30	NC	
#31	GND		
#32	NC		
#33	NC		
#34	GND		
#35	VIU_SDA		
#36	SPI0_MISO		
#37	SPI0_CSN		
#38	VIU_SCL		
#39	VCC_3.3V		
#40	VCC_3.3V		
更多圖片 More Pictures			

Part #: 8959, 5MP, IMX335 + MIPI, FPC

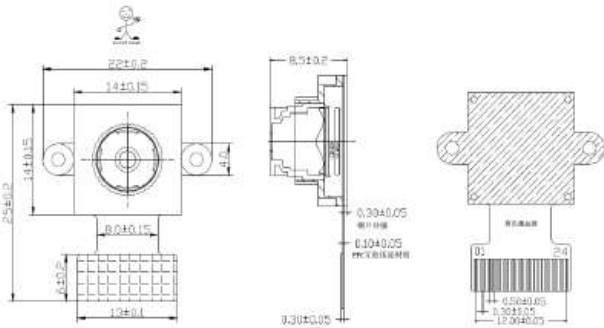

攝像頭參數 Parameter of Lens-Camera Module			圖片 Photo (Just for Reference)
型號 Model No	8959		
圖像傳感 Image Sensor	IMX335		
有效焦距 EFL	4.30 mm		
透光量 F.NO	2.4		
分辨率 Resolution	5 MP		
分辨率 Pixel	2592*1944		
視角 View Angle	D:73°		
相面尺寸 Lens Type	1/2.7"		
排線長度 FPC Length	5 mm		
畸變 Distortion	< 0.5%		
接口 Interface	MIPI		
引腳 Pins	#1	GND	
	#2	MCKL	
	#3	AVDD 2.8V	
	#4	DOVDD 1.8V	
	#5	VSYNC	
	#6	DVDD 1.2V	
	#7	SDA	
	#8	SCL	
	#9	PWDN	
	#10	RESET	
	#11	GND	
	#12	MCP	
	#13	MCN	
	#14	GND	
	#15	MDP0	
	#16	MDN0	
	#17	GND	
	#18	MDP1	
	#19	MDN1	
	#20	GND	
	#21	MDP2	
	#22	MDN2	
	#23	GND	
	#24	MDP3	
	#25	MDN3	
更多圖片 More Pictures	 <p>Technical drawings of the camera module showing dimensions:</p> <ul style="list-style-type: none"> Top view: Overall width 22±0.2, lens diameter 14±0.15, mounting hole diameter 6.0±0.15, bottom width 12±0.1, and total height 25±0.15. Side view: Lens diameter 6.0±0.2, lens thickness 0.30±0.05, and PCB thickness 0.30±0.05. Bottom view: Shows the FPC connector with dimensions 0.30±0.05, 0.10±0.025, 0.56±0.05, 0.30±0.15, and 1.30±0.05. 		

Part #: 9006, 5MP, OV5647 + MIPI, 25x24, Raspberry Pi

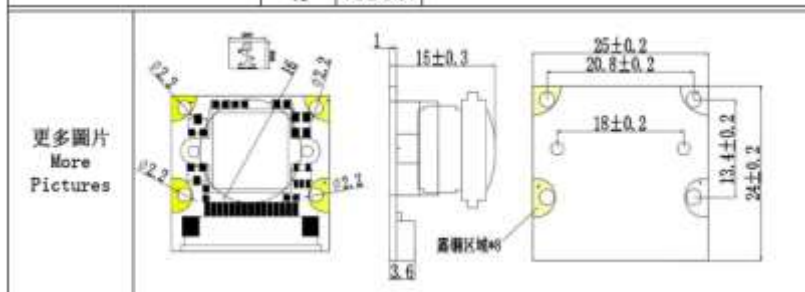
攝像頭參數 Parameter of Lens-Camera Module		圖片 Photo (Just for Reference)																														
型號 Model No	9006																															
圖像傳感 Image Sensor	OV5647																															
分辨率 Resolution	5MP																															
分辨率 Pixel	2592x1944																															
焦距尺寸 Lens Type	1/4 inch																															
對焦類型 Module Type	Fixed																															
天體尺寸 Overall Size	25x24 mm																															
電路板材質 PCB Material	FR4																															
電路板顏色 PCB Color	Black																															
接口 Interface	15 Pin																															
輸出格式 Output	VGA																															
圖像傳輸速率 Image Transfer Rate	30fps@24Mhz																															
功率消耗 Power Consumption	264 mW																															
接口定義 Pins	<table border="1"> <tr><td>1</td><td>GND</td></tr> <tr><td>2</td><td>MDN0</td></tr> <tr><td>3</td><td>MDP0</td></tr> <tr><td>4</td><td>GND</td></tr> <tr><td>5</td><td>MDN1</td></tr> <tr><td>6</td><td>MDP1</td></tr> <tr><td>7</td><td>GND</td></tr> <tr><td>8</td><td>MCN</td></tr> <tr><td>9</td><td>MCP</td></tr> <tr><td>10</td><td>GND</td></tr> <tr><td>11</td><td>PWDN</td></tr> <tr><td>12</td><td>DOVDD</td></tr> <tr><td>13</td><td>SCL</td></tr> <tr><td>14</td><td>SDA</td></tr> <tr><td>15</td><td>VCC 3.3V</td></tr> </table>		1	GND	2	MDN0	3	MDP0	4	GND	5	MDN1	6	MDP1	7	GND	8	MCN	9	MCP	10	GND	11	PWDN	12	DOVDD	13	SCL	14	SDA	15	VCC 3.3V
1	GND																															
2	MDN0																															
3	MDP0																															
4	GND																															
5	MDN1																															
6	MDP1																															
7	GND																															
8	MCN																															
9	MCP																															
10	GND																															
11	PWDN																															
12	DOVDD																															
13	SCL																															
14	SDA																															
15	VCC 3.3V																															

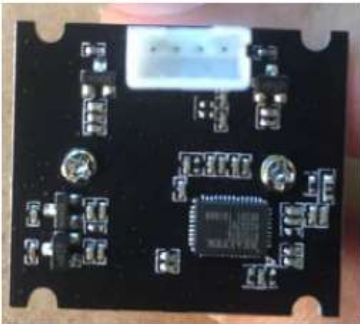

Part #: 9017, 5MP, OV5648 + USB, 30x25

參數 Parameter		圖片 Photo (Just for Reference)
型號 Model No	9017	
傳感器規格 Image Device	1/4" CMOS	
感光芯片 Chip	OV5648	
圖像制式 Output Type	MJPEG/ YUV	
像素尺寸 Cell Size	1.4um x 1.4um	
解析度 Pixel	5MP	
最大分辨率 Max Resolution	2592x1944	
鏡頭類型 Lens Focus	Fixed	
最低亮度 Sensitivity	690mV/lux-sec	
白平衡 AEC/Gain/White Balance	Auto	
幀率 Image Transfer Rate (MJPEG)	2592x1944: 15 fps	
	1080p: 30 fps	
	980p: 45 fps	
	720p: 60 fps	
接口類型 Interface	USB 2.0 High Speed	
驅動協議 Driver Implement	USB Video Class	
操作系統 Compatible OS	Windows, Android	
電壓 Power Supply	DC 5V	
工作電流 Consumption Current	130mA	
尺寸 Dimensions	30x25mm	
重量 Weight	Approx. 20g	
AMSL Lens Hong Kong Office Address: 701, 7/F, TOWER 2, SILVERCORD, 30 CANTON ROAD, TSIM SHA TSUI, KOWLOON Mainland Factory Address: #47, ROAD SHI YANG, HU MEN TOWN, CITY DONG GUAN, PROVINCE GUANG DONG, 523900 PHONE: +852 6672 1979/+86 185 2016 9594 WEBSITE: www.ams-lens.biz		

Part #: 9014, 8MP, GC8034 + MIPI, FPC, AF

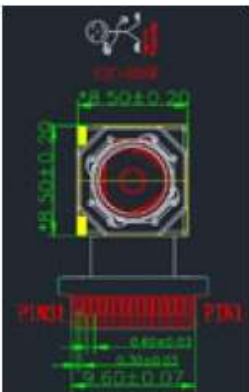
攝像頭參數 Parameter of Lens-Camera Module		圖片Photo (Just for Reference)	
型號 Model No	9014		
圖像傳感 Image Sensor	GC8034		
有效焦距 EFL	2.50mm		
透光量 F.NO	2.2		
分辨率 Resolution	8MP		
分辨率 Pixel	3264x2448		
視角 ViewAngle	84.4°		
相面尺寸 Lens Type	1/4 inch		
對焦類型 Module Type	Auto Focus		
大體尺寸 Overall Size	8.50x8.50x4.85mm		
接口 Interface	MIPI		
引腳 Pins	#1		VDDMOT 2.8V
	#2		VCAMA
	#3		VCAMD 1.2V
	#4		VCAMIO
	#5		SCL_CAMI
	#6		SDA_CAMI
	#7		PWON
	#8		RST
	#9		GND
	#10		MCLK
	#11		GND
	#12		CLK_N
	#13		CLK_P
	#14		GND
	#15		DATA0_N
	#16		DATA0_P
	#17		GND
	#18		DATA1_N
	#19		DATA1_P
	#20	GND	
#21	DATA2_N		
#22	DATA2_P		
#23	GND		
#24	DATA3_N		
#25	DATA3_P		
#26	GND		
#27	FLASH+		
#28	FLASH+		
#29	FLASH-		
#30	FLASH-		
#31	AF-VCC		

更多圖片
More
Pictures

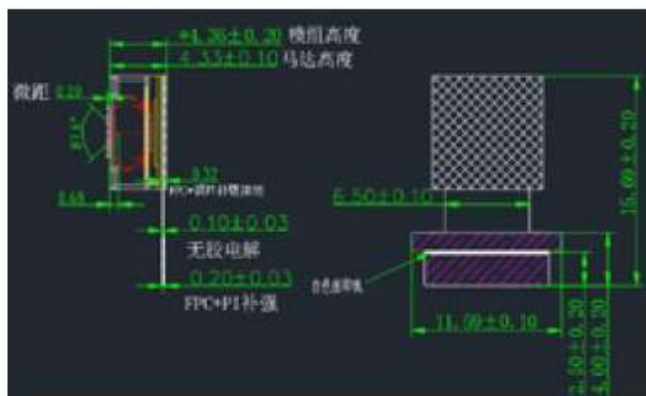

Camera Module, 11MP

Part #: 9025, 11MP, IMX214 + USB, 38x38

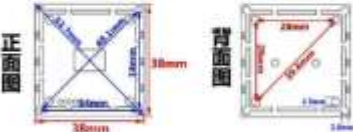
參數 Parameter		圖片 Photo (Just for Reference)
型號 Model No	9025	 
傳感器規格 Image Device	CMOS	
感光芯片 Chip	Sony IMX214	
圖像制式 Output Type	MJPEG/ YUY2	
像素尺寸 Cell Size	1.12um x 1.12um	
解析度 Pixel	11MP	
最大分辨率 Max Resolution	3840x2880	
鏡頭類型 Lens Focus	Auto Focus	
遠像距離 Working Distance	1cm to ∞	
黑白模式 Monochromatic	IR 650nm Filter	
白平衡 Gain Control Gain	Auto Auto	
速率 Image Transfer Rate (MJPEG)	3840x2160 @25fps 3840x2880 @20fps	
接口類型 Interface	USB 2.0(4pin-2mm)	
驅動協議 Driver Implement	USB Video Class	
操作系統 Compatible OS	Windows, Android, IOS	
電壓 Power Supply	DC 5V	
工作電流 Consumption Current	160mA (VGA)	
尺寸 Dimensions	38mm x 38mm	
重量 Weight	Approx. 35g	

AMSL Lens

Hong Kong Office Address:
 T01, 7/F, TOWER 2, SILVERCORD, 30 CANTON ROAD, TSM SHA TSUI, HONGKONG
 Mainland Factory Address:
 #47, ROAD SHE YANG, HU MEN TOWN, CITY DONG GUAN, PROVINCE GUANG DONG, 523900
 PHONE: +852 0672 1070/+86 185 2010 0504
 WEBSITE: www.amslens.biz



Camera Module, 13MP

Part #: 8980, 13MP, OV13850 + MIPI, FPC, AF

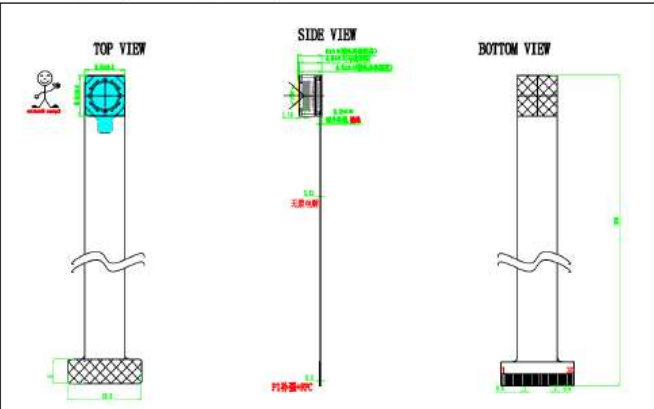
攝像頭參數 Parameter of Lens-Camera Module		圖片 Photo (Just for Reference)	
型號 Model No	8980		
圖像傳感 Image Sensor	OV13850		
有效焦距 EFL	3.40 mm		
透光量 F.NO	2.2		
分辨率 Resolution	13 MP		
分辨率 Pixel	4224*3136		
視角 View Angle	D:78°		
相面尺寸 Lens Type	1/3.06 inch		
排線長度 FPC Length	25 cm		
畸變 Distortion	< 1.5%		
接口 Interface	MIPI		
引腳 Pins	#1		NC
	#2		AF_VDD
	#3		DVDD 1.2
	#4		DOVDD 1.8V
	#5		NC
	#6		AGND
	#7		AVDD 2.8V
	#8		GND
	#9		SDA
	#10		SCL
	#11		RESET
	#12		NC
	#13		GND
	#14		MCLK
	#15		GND
	#16		RDP3
	#17		RDN3
	#18		GND
	#19		RDP2
	#20		RDN2
	#21		GND
	#22		RDP1
	#23	RDN1	
	#24	GND	
	#25	CLK_P	
	#26	CLK_N	
	#27	GND	
	#28	RDP0	
	#29	RDN0	
	#30	GND	
更多圖片 More Pictures			

Dual Camera Module

Part #: 8981, 2MP, GC2053 + PS5268LT + USB, 80x17, 30FPS

型號 Model No		8981	
圖像傳感 Image Sensor	GalaxyCore GC2053	PixArt PS5268LT	
傳感顏色 Image Color	RGB (Color)	Mono (Black & White)	
傳感器尺寸 Sensor Size	1/2"	1/2"	
解析度 Pixel	1920x1080P	1920x1080P	
幀數 Frame Rate	1920x1080 at 30fps 1280x960 at 30fps 1280x720 at 30fps 1024x768 at 30fps 800x600 at 30fps 640x480 at 30 fps 352x288 at 30fps 320x240 at 30fps 160x120 at 30fps	1920x1080 at 30fps 1280x960 at 30fps 1280x720 at 30fps 1024x768 at 30fps 800x600 at 30fps 640x480 at 30 fps 352x288 at 30fps 320x240 at 30fps 160x120 at 30fps	
最大動態範圍 Max Dynamic Range	85DB	85DB	
輸出格式 Output	YUY2, MJPEG	YUY2, MJPEG	
信噪比 SNR	38DB	38DB	
增益/曝光/白平衡 AGC/REC/White balance	auto control	auto control	
最低照度 Min. Illumination	>=0.1LUX	>=0.1LUX	
功率 Power	Max 0.95w	Max 1.5w	
鏡頭 Lens	鏡頭結構 Lens Construction	2G2P+IR850nm	2G2P+IR850nm
	螺紋大小 Mounting	M8*P0.25	M8*P0.25
	視場角 FOV	D: 75°/ H:63°/ V:41°	D: 75°/ H:63°/ V:41°
	鏡頭光學 Lens F/No	2.2	2.2
	焦距 Lens ELP	4.3mm	4.3mm
	畸變TV Distortion	<=0.5%	<=0.5%
大體尺寸 Overall Size	80.00mm × 16.00mm × 10.2mm		
電路板材質 PCB Material	FR4		
電路板顏色 PCB Color	Black		
紅外線光譜 IR-LED Wavelength	IR850nm		
外觀控制方式 IR-LED Control Mode	Auto On on the mono mode		
紅外線可視範圍 IR-LED Range	3M @H, 3M @V		
紅外線功率 IR-LED Power	Total 6PCS: Max 420mA		
介質位置 Pins	1	VCC	5v
	2	D-	
	3	D+	
	4	GND	



更多圖片
More Pictures

NO.	說明
1	100-200
2	100-200
3	100-200
4	100-200

NO.	說明
1	100-200
2	100-200
3	100-200
4	100-200

NO.	說明
01	LED
02	LED

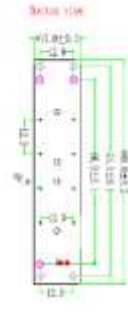
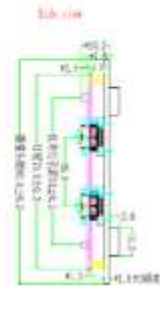
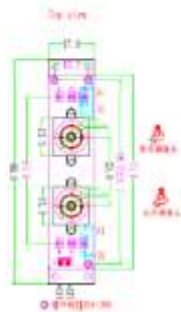

Part #: 9001, 1MP, OV9281 + USB, 88x16, Sync, BW

攝像頭參數 Parameter of Lens-Camera Module		圖片 Photo (Just for Reference)
型號 Model No	9001	
圖像傳感 Image Sensor	OV9281	
圖像色彩 Image Color	Black & White	
分辨率 Resolution	1MP per lens	
分辨率 Pixel	2560 x 720P	
雙目同步 Dual Lens Frame Difference	Completely Sync	
幀數 Frame Rate	MJPG 2560x720P @60fps	
相面尺寸 Lens Type	1/4 inch	
對焦類型 Module Type	Fixed	
視角 View Angle	120°	
鏡頭結構 Lens Construction	TBD	
鏡頭光圈 Lens F/No	TBD	
焦距 Lens ELF	TBD	
紅外濾光片 IR Filter	650 nm	
大體尺寸 Overall Size	80x16xTBD mm	
雙目距離 Dual Lens Distance	63 mm	
電路板材質 PCB Material	FR4	
電路板顏色 PCB Color	Black	
接口 Interface	USB 2.0	
輸出格式 Output	YUY2/MJPEG	
接口定義 Pins	1	VCC_5v
	2	D-
	3	D+
	4	GND
	5	GND

更多圖片
More Pictures

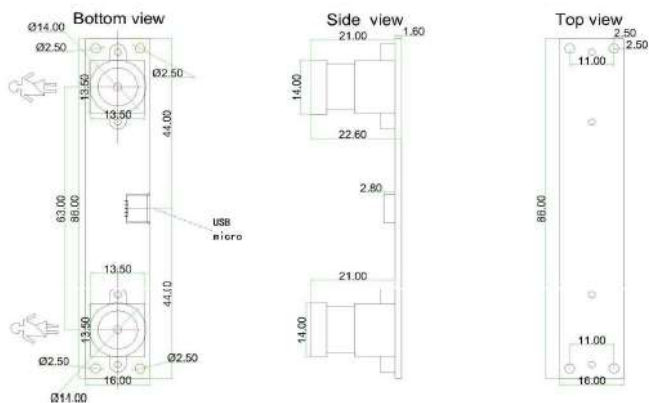

Part #: 9002, 2MP, OV4689 + USB, 30FPS

攝像頭參數 Parameter of Lens-Camera Module		圖片 Photo (Just for Reference)	
型號 Model No	9002		
圖像傳感 Image Sensor	OV4689		
分辨率 Resolution	2MP per lens		
分辨率 Pixel	1920x1080P		
幀數 Frame Rate	1920x1080P @30fps		
相面尺寸 Lens Type	1/3 inch		
對焦類型 Module Type	Fixed		
視角 View Angle	120°		
鏡頭結構 Lens Construction	4P		
鏡頭光圈 Lens F/No	2.8		
焦距 Lens ELF	3.6 mm		
紅外線光片 IR Filter	650 nm		
大體尺寸 Overall Size	80x22x24.6 mm		
電路板材質 PCB Material	FR4		
電路板顏色 PCB Color	Black		
接口 Interface	USB 2.0		
輸出格式 Output	YUY2/MJPEG		
接口定義 Pins	1		VCC_5v
	2		D-
	3		D+
	4	GND	
	5	GND	

更多圖片
More
Pictures

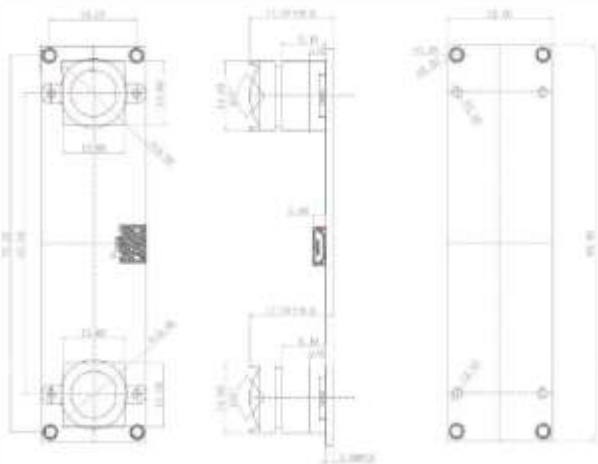

Zoom-In Camera

Part #: 7096, 5MP Zoom x20 USB Camera

攝像頭參數 Parameter of Camera		圖片 Photo (Just for Reference)
型號 Model No	7096	
分辨率 Resolution	5MP, 2592*1944	
方案 ISP & Sensor	SigmaStar SSC30KD + 1/2.8" IMX335	
視頻格式 Video Format	2592x1920/30fps; 2304x1296/30fps; 2048x1536/30fps; 640x480/VA/30fps; 640x360/30fps; 320x240/2V/VA/30fps	
最低照度 Minimum illumination	Color 0.06Lux@F1.2, Mono 0.02@F1.2	
信噪比 S/N ratio	>45db(AGC OFF)	
焦距 Focal-Length Control	4.7~94.06mm	
光圈 Aperture Control	F1.6~2.7	
鏡頭 Lens	20x optical zoom	
對焦距離 Focusing Distance	1m (wide) ~ Infinity (tele)	
視場角 FOV	D: 93° (wide); D: 6.5° (tele);	
接口類型 Interface	USB 2.0	
驅動協議 Driver Implement	UVC 1.1	
操作系統 Compatible OS	Windows 7 later	
電腦端軟件 PC Client App	AMCAP, or universal app	
電源 Power Supply	USB 5.0V/0.8A	
功率消耗 Power Consumption	4W	
尺寸 Dimension	87.5*50*60mm	
重量 Weight	305g	
更多圖片 More Pictures		



Part #: 7097, 8MP Zoom x20 USB Camera

攝像頭參數 Parameter of Carema		圖片 Photo (Just for Reference)
型號 Model No	7097	
分辨率 Resolution	8MP, 3864*2192	
方案 ISP & Sensor	SigmaStar SSC9381 + 1/2.8" IMX415	
視頻格式 Video Format	H.264—4K@30fps, 1080P@50fps, 720P@30fps MJPEG—4K@30fps, 1080P@50fps, 720P@30fps YUV—1080P@30fps, 720P@30fps	
最低照度 Minimum illumination	0.5LUX	
信噪比 S/N ratio	>50dB	
增益調整 Gain	Auto / manual	
快門速度 Shutter Speed	1/2 to 1/200 sec	
焦距 Focal-Length Control	4.9~95mm	
光圈 Aperture Control	F1.8~3.9	
曝光控制 AE (Auto exposure mode)	Auto, Manual, Priority Mode (shutter / iris)	
鏡頭 Lens	20x optical zoom	
對焦距離 Focusing Distance	1m (wide) ~ Infinity (tele)	
視場角 FOV	D: 75° (wide); D: 4.5° (tele);	
接口類型 Interface	USB 2.0	
驅動協議 Driver Implement	UVC 1.1	
操作系統 Compatible OS	Windows 7 later	
電腦端軟件 PC Client App	AMCAP, or universal app	
電源 Power Supply	USB 5.0V/1A	
功率消耗 Power Consumption	5W	
尺寸 Dimension	110*48*42MM	
重量 Weight	95G	

更多圖片 More Pictures			
--------------------------	--	--	--

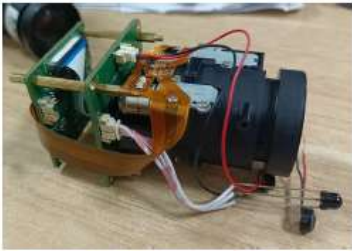
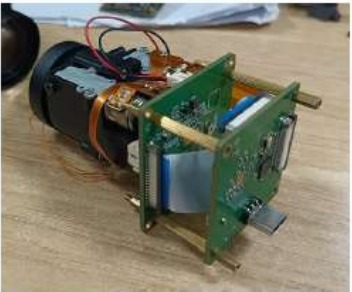
Part #: 7098, 1080P Zoom x10 USB Camera

攝像頭參數 Parameter of Carema		圖片 Photo (Just for Reference)
型號 Model No	7098	
分辨率 Resolution	2MP, 1920*1080	
方案 ISP & Sensor	Hi3518E + 1/2.8" IMX307	
視頻格式 Video Format	YUV---360p, 480P, 720p MJPEG---360P, 480P, 720P, 1080P h264---360P, 480P, 720P, 1080P	
最低照度 Minimum illumination	0.05LUX at daytime, 0.013LUX at night	
信噪比 S/N ratio	>50dB	
增益調整 Gain	Auto / manual	
快門速度 Shutter Speed	1/1 to 1/10,000 sec	
焦距 Focal-Length Control	4.9~47.04mm	
光圈 Aperture Control	F2.8~3.2	
曝光控制 AE (Auto exposure mode)	Auto, Manual, Priority Mode (shutter / iris)	
鏡頭 Lens	10x optical zoom	
對焦距離 Focusing Distance	1m (wide) ~ Infinity (tele)	
視場角 FOV	D: 67.6°, H: 54.8°, V: 41.2° (wide); D: 7.15°, H: 5.8°, V: 4.38° (tele);	
接口類型 Interface	USB 2.0	
驅動協議 Driver Implement	USB Video Class	
操作系統 Compatible OS	Windows XP later	
電腦端軟件 PC Client App	AMCAP, or universal app	
電源 Power Supply	USB 5.0V	
功率消耗 Power Consumption	2.5W	
尺寸 Dimension	43*43*85MM	
重量 Weight	75G	

更多圖片 More Pictures		
--------------------------	--	--

Order Form

Last Name _____

First Name _____ M.I. _____

Address _____ Apt./Unit _____

City _____ State _____ ZIP Code _____

Phone _____ E-Mail _____

Method of payment Check VISA MasterCard

Credit Card # _____ Exp. Date _____

Name as it appears on card _____

Signature

Part No.	Price	Qty.	Amount
Subtotal			
Tax			
Shipping			
Total			



We give you three easy ways to order

- **Visit us on www.amsl-lens-cam.biz**
- **Fill out the order form and send it to email sales@amperems.biz or inglittlemoon@163.com**
- **Call us +852 6672 1979/+86 150 5918 7808**

AMSL Lens-Cam

Hong Kong Address: WUI WAH FACTORY BUILDING, 2/F, NO.41 WING HONG STREET, LAI CHI KOK

China Factory Address: #47, ROAD SHI YANG, HU MEN TOWN, CITY DONG GUAN, PROVINCE GUANG DONG, CHINA, 523900

HK Contact No.: +852 6672 1979

China Contact No.: +86 150 5918 7808

Website: www.amsl-lens-cam.biz